



SHIP PARTICULARS

6K-120/160

Name	Built	IMO-No.	Flag	Name	Built	IMO-No.	Flag
Industrial Ace ¹⁾	1999	9193800	Antigua & Barbuda	Industrial Aim ³⁾	1999	9204934	Antigua & Barbuda
Industrial Ama ²⁾	1998	9193812	Antigua & Barbuda				

GENERAL INFORMATION

Type	Box-Hold MPP Tweendecker
Class	RINA ^{1),2)} DNV GL ³⁾

TONNAGE

DWT	about 6,288 mt
GT	4,246 ^{1),2)} 4,251 ³⁾
NT	2,189

MAIN DATA

LOA	99.98 m
Beam	17.00 m
Summer Draft	7.28 m
Max Speed	About 13.5 knots

HOLDS/HATCHES

Number	1 Hold / Hatch
Hold No.1	58.10 x 14.00 x 9.00 m
Hatch No.1	58.40 x 14.30 m

CARGO CAPACITY

with Tweendeck	6,622 cbm / 233,853 cbft	Bale
-----------------------	--------------------------	------

FLOOR SPACE

Under Deck	1,510 m ²
On Deck	1,076 m ²
Total	2,586 m ²

MAX. PERMISSABLE LOAD

Tanktop	15.3 mt / m ²
Tweendeck	2.5 mt / m ²
Hatchcovers	1.7 mt / m ²

CONTAINERS CAPACITY

Total	361 TEU
Reefer Plugs	40

CARGO HANDLING GEAR

Cranes	2 X 60 mt ^{1),2)} 2 x 80 mt ³⁾ (all portside)
Combined Lift Capacity	120 mt ^{1),2)} 160 mt ³⁾

SPECIAL EQUIPMENT/FEATURE

IMO fitted	Yes
Lakes Fitted	
CO2 Fitted	Yes
A60 Bulk Head	No
Grain Fitted	Yes
Bowthruster	500 KW

All details including speed are given in good faith and can vary on the individual vessels. They are to be considered „about“, are given without guarantee and must not be used as basis for charterparties or contracts without Intermarine's explicit written authority. For further information, please contact info@intermarine.com // **Last Revised: March 2024**

6K-120/160

INDUSTRIAL ACE¹⁾ INDUSTRIAL AMA²⁾ INDUSTRIAL AIM³⁾

FRONT

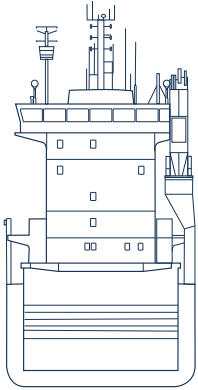

SIDE

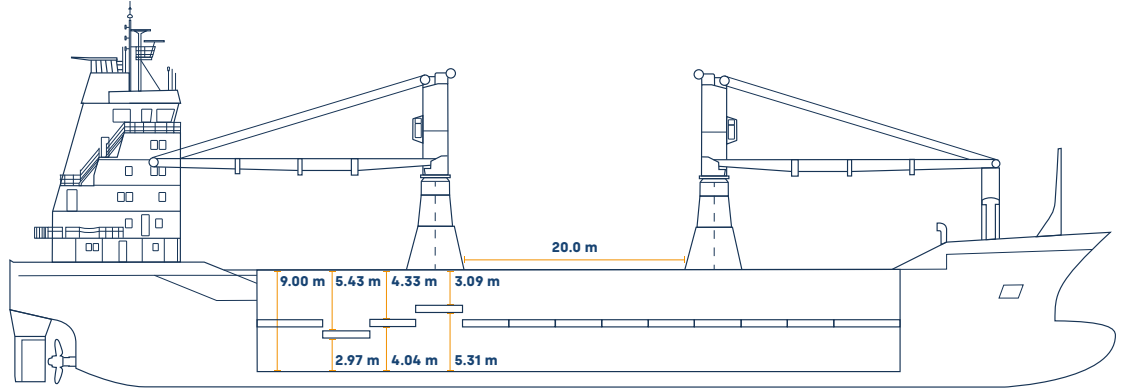

MAINDECK

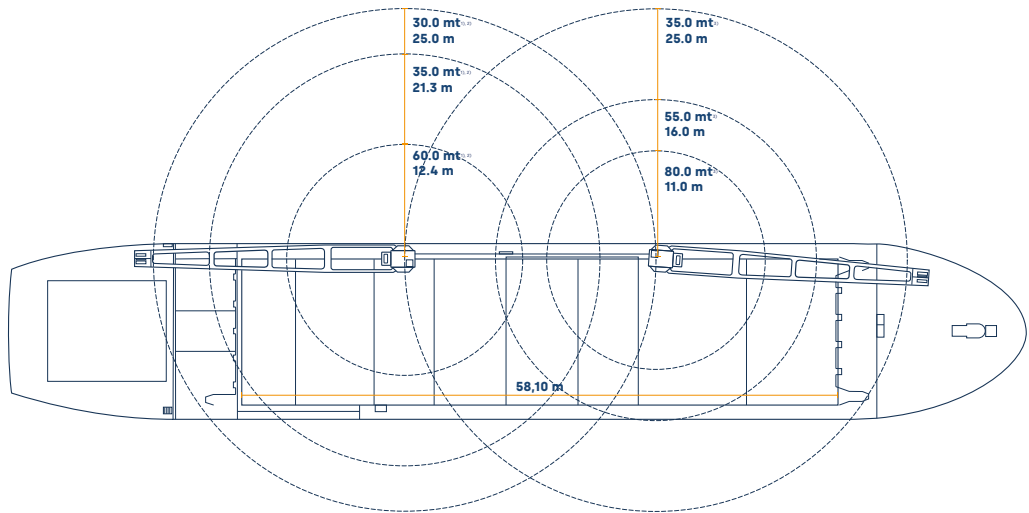

TWEENDECK

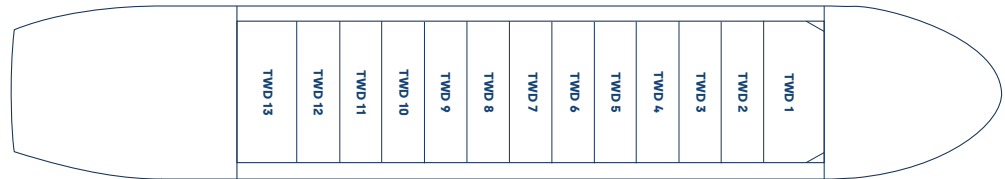

TANKTOP

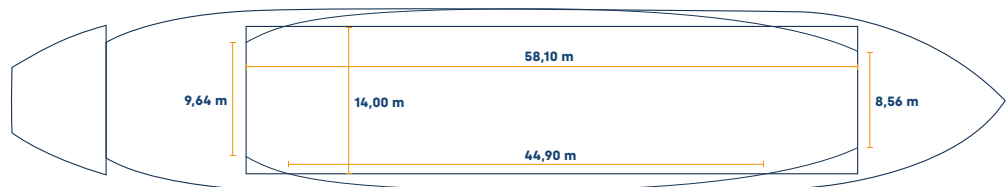

All details including speed are given in good faith and can vary on the individual vessels. They are to be considered „about“, are given without guarantee and must not be used as basis for charterparties or contracts without Intermarine's explicit written authority. For further information, please contact info@intermarine.com // **Last Revised: March 2024**